

# DETERMINANT EXPANSIONS OF SIGNED MATRICES AND OF CERTAIN JACOBIANS

J. WILLIAM HELTON<sup>1</sup>, IGOR KLEP<sup>2</sup>, AND RAUL GOMEZ

ABSTRACT. This paper treats two topics: matrices with sign patterns and Jacobians of certain mappings on the nonnegative orthant  $\mathbb{R}_{\geq 0}^d$ . The main topic is counting the number of positive and negative coefficients in the determinant expansion of sign patterns and of these Jacobians. The paper is motivated by an approach to chemical networks initiated by Craciun and Feinberg. We also give a graph-theoretic test for determining when the sign pattern of the Jacobian of a chemical reaction dynamics is unambiguous.

## 1. INTRODUCTION

This paper treats two topics: matrices with sign patterns and Jacobians of certain mappings. The main topic is counting the number of positive and negative coefficients in their determinant expansion, but other types of results occur along the way. It is motivated by an approach to chemical networks initiated by Craciun and Feinberg, see [CF05, CF06], and extensions observed in [CHW08].

**1.1. Determinants of Sign Patterns.** The first topic, see §2, is purely matrix theoretic and generalizes the classical theory of sign definite matrices [BS95]. This subject considers classes of matrices having a fixed sign pattern (two matrices are in a given class if and only if each of their entries has the same sign), then one studies determinants. Call a **sign pattern** a matrix  $A$  with entries which are  $\pm A_{ij}$  or 0, where  $A_{ij}$  are free variables. To a matrix  $B$  we can associate its sign pattern  $A = \text{SP}(B)$  with  $\pm A_{ij}$  or 0 in the correct locations.

*Example 1.1.* Let  $B = \begin{bmatrix} -1 & 10 \\ 0 & -7 \end{bmatrix}$ . Then  $A = \text{SP}(B) = \begin{bmatrix} -A_{11} & A_{12} \\ 0 & -A_{22} \end{bmatrix}$ .

If the sign pattern  $A$  is square, then the determinant of  $A$  is a polynomial in variables  $A_{ij}$ , which we call the **determinant expansion** of  $A$ . We call a square invertible matrix **sign-nonsingular (SNS)** if every term in the determinant expansion of its sign pattern has the same nonzero sign. There is a complete and satisfying theory of these which associates a digraph to a square sign pattern and a test which determines precisely if the matrix is SNS, see [BMQ68, BS95]. Furthermore, SNS matrices can be recognized in polynomial-time [RST99].

In this paper we refine the [BMQ68] characterization of SNS matrices by analyzing square sign patterns and giving a graph-theoretic test to count the number of positive and negative signs in their determinant expansions; Theorem 2.6. We extend the result to nonsquare matrices and call our test on a matrix the **det sign test**.

In the appendix we say precisely when the product of a sign pattern with its transpose admits a sign pattern, see Theorem 5.1.

---

*Date:* 21 March 2009.

2000 *Mathematics Subject Classification.* 15A48, 80A30.

*Key words and phrases.* sign patterns, signed matrices, determinants of Jacobians, chemical reaction networks.

<sup>1</sup>Partially supported by the NSF (DMS-0700758, DMS-0757212) and the Ford Motor Co.

<sup>2</sup>Financial support from the state budget by the Slovenian Research Agency (project No. Z1-9570-0101-06).

**1.2. Jacobians of reaction form differential equations.** The second topic, §3, in this paper applies this to systems of ordinary differential equations which act on the nonnegative orthant  $\mathbb{R}_{\geq 0}^d$  in  $\mathbb{R}^d$ :

$$(1.1) \quad \frac{dx}{dt} = f(x),$$

where  $f : \mathbb{R}_{\geq 0}^d \rightarrow \mathbb{R}^d$ . The differential equations we address are of a special form found in chemical reaction kinetics:

$$(1.2) \quad \frac{dx}{dt} = Sv(x),$$

where  $S$  is a real  $d \times d'$  matrix and  $v$  is a column vector consisting of  $d'$  real-valued functions. We say that system (1.1) has **reaction form** provided it is represented as in (1.2) with  $v(x) = (v_1, \dots, v_{d'})$  and

$$(1.3) \quad v_j \text{ depends exactly on variables } x_i \text{ for which } S_{ij} < 0.$$

Call  $S$  the **stoichiometric matrix** and the entries of  $v(x)$  the **fluxes**. We always assume the fluxes are continuously differentiable.

Our second main result, Theorem 3.2, describes which  $S$  have the property that the Jacobian matrix  $f'(x) = Sv'(x)$  has a sign pattern, meaning that each entry  $f'_{ij}(x) = \frac{\partial f_i}{\partial x_j}(x)$  has sign independent of  $x$  in the positive orthant. The characterization is graph-theoretic and simple. Extensions of these results can be found in [HKKprept]. The question was motivated by works of Sontag and collaborators [AnS03, ArS06, ArS07].

Our third main result here, Theorem 3.15, when specialized to square invertible  $S$  counts the number of plus and minus signs in the determinant expansion of the Jacobian  $f'(x) = Sv'(x)$  of a reaction form  $f(x) = Sv(x)$  in the terms of a bipartite graph associated to  $S$  and the det sign test. We use this to obtain results on the determinant expansion for general nonsquare  $S$ .

We present many examples which illustrate features of our results and limitations on how far one can go beyond them.

**1.3. Chemistry.** The reaction form differential equations subsume chemical reactions where no chemical appears on both sides of a reaction, e.g. catalysts. Furthermore, in many situations all fluxes  $v_j(x)$  are monotone nondecreasing in each  $x_i$  when the other variables are fixed, that is,  $v'(x)$  has all entries nonnegative. This happens in classical mass action kinetics or for Michaelis-Menten-Hill type fluxes. See [Pa06] for an exposition.

A key issue with reaction form equations is how many equilibria do they have in the positive orthant  $\mathbb{R}_{> 0}^d$ . It was observed in [CF05, CF06, CF06iee] that in many simple chemical reactions the determinant of  $f'$  has constant sign on the positive orthant and as a consequence of a strong version of this, any equilibrium which exists is unique. Other approaches exploiting this determinant hypothesis (under weaker assumptions) are in [BDB07, CHW08]. Roughly speaking, if the determinant of the Jacobian  $f'$  does not change sign on a compact region  $\Omega$ , then degree theory applies and bears effectively on this issue; the full orthant  $\mathbb{R}_{> 0}^d$  can easily be approximated by expanding  $\Omega$ 's.

The degree argument is very flexible and probably extends to many situations. Fragile, however, is establishing constraints on the sign of the determinant. A key tool is the **determinant expansion** of (1.2), namely, the expression  $\det(SV(x))$  as a polynomial in the functions  $V_{ij}(x)$ , which are the entries of the matrix function  $V(x) = v'(x)$ . The main issue is the sign of the terms in the determinant expansion: are they all the same or if not are there few ‘‘anomalous’’ signs? The [CF05, CF06, CF06iee] papers dealt with chemical reaction networks where the determinant expansion has all plus or all minus signs, that is, no anomalous signs, but the papers do give some examples where this is not true. In [CHW08] it is observed that in each of these Craciun and Feinberg examples the determinant expansion has very few anomalous signs. When this happens, then §6 of [CHW08] gave some methods, which are effective in many cases, to prove existence and uniqueness of equilibria. For example, if the determinant expansion has one minus sign and many plus signs, and if

$$v_j(x) = k_j m_j(x),$$

where  $m_j$  is a monomial in  $x$  and  $k_j > 0$ , then for a large collection of  $k_j > 0$ , we get  $\det(SV(x))$  is positive on large regions (which in particular situations can be estimated).

Our main results, Theorem 3.15 etc., on  $\det(SV(x))$  were motivated by a desire to develop tools for counting anomalous signs. While the paper is not aimed at chemical applications, many of the examples of matrices  $S$  we use to illustrate our work are stoichiometric matrices for chemical reactions.

The paper [BDB07] identified chemical reaction determinant expansions initiated by [CF05, CF06] with classical matrix determinant expansion theory and sign patterns. This is described in the book [BS95] and pursued into new directions in a variety of recent papers such as [BJS98, CJ06, KOSD07]. The bipartite graph conventions in this paper are a bit different than conventional, but were chosen to be reasonably consistent with [CF06].

The authors wish to thank Vitaly Katsnelson for diligent reading and suggestions. We also thank two anonymous referees whose useful comments improved the presentation of the paper.

## 2. MATRICES WITH SIGN PATTERNS

This section gives the set-up and our main results on sign patterns as described in the introduction.

Let  $t(A)$ , respectively  $m_{\pm}(A)$ , denote the number of nonzero terms, respectively positive or negative signs, in the determinant expansion of the square sign pattern  $A$ . Recall a **sign definite (SD)** matrix  $A$  is one with either  $m_-(A) = 0$  or  $m_+(A) = 0$  or  $\det(A) = 0$ . The number of **anomalous signs**  $m(A)$  of a square sign pattern  $A$  is defined to be

$$m(A) := \min\{m_-(A), m_+(A)\}.$$

We say  $A$  is  **$j$ -sign definite** if it has  $j$  anomalous signs, that is  $m(A) = j$ .

**Question (J-sign):** *Given a sign pattern  $S$  is every square submatrix sign definite, or more generally what is the largest  $j$  for which  $S$  contains a  $j$ -sign definite square matrix.*

We shall convert this question to an equivalent graph theoretic problem and give a more refined result for square sign patterns  $A$  which counts  $m_{\pm}(A)$ .

**2.1. Basics on graphs, matrices and determinants.** To this end we use the standard notion of bipartite graphs [HGBM06]. Given a sign pattern  $S$  let  $G(S)$  denote its **signed bipartite graph**. It is a signed bipartite graph with one set of vertices  $C(S)$  based on columns and the other set of vertices  $R(S)$  based on rows. There is an edge joining column  $c$  and row  $r$  if and only if the  $(r, c)$  entry  $S_{rc}$  of  $S$  is nonzero. The sign of this edge is the sign of  $S_{rc}$ . This is a simplified version of the species-reaction (SR) graph in [CF06]. If two edges meeting at the same column have the same sign, they are called a **c-pair**. By a **cycle** we mean a closed (simple) path, with no other repeated vertices than the starting and ending vertices (sometimes also called a simple cycle, circuit, circle, or polygon). A cycle that contains an even (respectively odd) number of c-pairs is called an **e-cycle** (respectively **o-cycle**). Recall a **matching** in a bipartite graph is a set of edges without common vertices. Equivalently it is an injective mapping from one of the vertex sets to the other respecting the graph. A matching in a bipartite graph is called **perfect** if it covers all vertices in the smaller of the two vertex sets. A  $k \times k$  square submatrix  $A$  of  $S$  corresponds to  $k$  column nodes  $C(A)$  and  $k$  row nodes  $R(A)$ ; there is an associated sub-bipartite graph  $G(A)$  of  $G(S)$ .

*Example 2.1.* The following is an example taken from [CF05, Table 1.1.(v)] which illustrates these definitions. Given

$$S = \begin{bmatrix} -1 & -1 & 0 & 0 \\ -1 & 0 & 1 & 0 \\ 0 & -1 & -1 & -1 \\ 0 & 0 & -1 & 1 \\ 0 & 0 & 0 & -1 \\ 1 & 0 & 0 & 0 \\ 0 & 1 & 0 & 0 \end{bmatrix},$$

the signed bipartite graph  $G(S)$  is as follows:

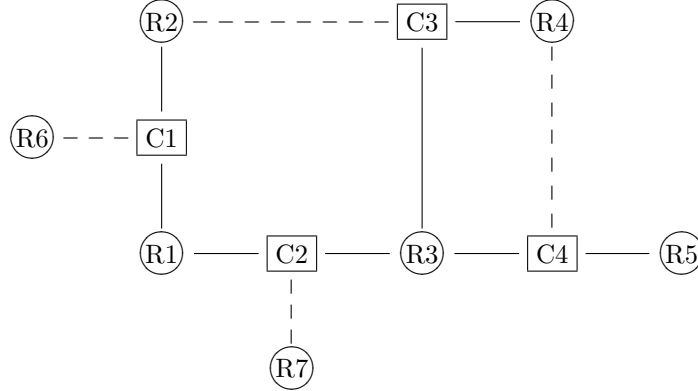

Here the dashed lines denote positive edges and full lines represent negative edges.

The edges  $C3-R4$  and  $C3-R3$  are a  $c$ -pair, while  $C3-R4$  and  $C3-R2$  are not a  $c$ -pair. The cycle  $C3-R4-C4-R3-C3$  has one  $c$ -pair, so is an  $o$ -cycle. On the other hand, the cycle  $C1-R1-C2-R3-C3-R2-C1$  has two  $c$ -pairs and so is an  $e$ -cycle. ■

We use repeatedly the basic fact of linear algebra that if  $A$  is an  $n \times n$  square matrix, then

$$(2.1) \quad \det A = \sum_{\sigma \in S_n} \text{sign}(\sigma) \prod_{i=1}^n A_{i,\sigma(i)},$$

where  $S_n$  is the group of permutations on  $\{1, 2, \dots, n\}$  and  $A_{i,j}$  denotes the  $(i, j)$  term of  $A$ .

*Remark 2.2.* (1) The bipartite graph  $G(A)$  of a square sign pattern  $A$  has no perfect matching if and only if  $\det A = 0$ . This classic observation arises from the fact that there is a 1-1 correspondence between nonzero terms in the determinant expansion of  $A$  and perfect matchings of  $G(A)$ .

- (2) If the bipartite graph of a rectangular matrix does not have a perfect matching, then the determinants of all of its maximal square submatrices are 0.
- (3) The number of terms in the determinant expansion of a square sign pattern  $A$  is the number of perfect matchings of  $G(A)$ . ■

**2.2. SNS matrices vs. e-cycles.** Let us call a square invertible matrix **sign-nonsingular (SNS)** if every nonzero term in the determinant expansion of its sign pattern has the same sign [BS95, Lemma 1.2.4]. If all square submatrices of (a not necessarily square matrix)  $S$  are either SNS or singular, then  $S$  is a **total signed compound (TSC)** matrix [DGESVD99]. Note that in [BDB07], TSC matrices are called strongly sign-determined (SSD).

**Proposition 2.3.** *A sign pattern  $S$  is TSC if and only if the signed bipartite graph  $G(S)$  has no e-cycle.*

*Proof.* This fact is essentially classical, cf. [BS95, Theorem 3.2.1]. Also, it is a special case of Theorem 2.6. ■

**2.3. Many Cycles: Square Matrices.** Next we turn to the more general situation where  $e$ -cycles occur in  $G(A)$ . The bipartite graph  $G(A)$  enables us to count the number of positive, negative and anomalous signs in the determinant expansion of a square sign pattern  $A$ . We permute and re-sign to make sure all diagonal entries of  $A$  are negative. Thus these diagonal entries correspond precisely to a perfect matching  $\mathcal{W}$  in  $G(A)$ . A cycle in  $G(A)$  that contains each edge  $(c, \mathcal{W}(c))$  in  $G(A)$  corresponding to any column  $c$  it passes through, is called **interlacing** with respect to  $\mathcal{W}$ , or  **$\mathcal{W}$ -interlacing** for short.

*Remark 2.4.* To a given signed bipartite graph  $G$  we can associate (uniquely up to transposition and a permutation of rows and columns) a sign pattern  $A$  with  $G(A) = G$ . The **number of anomalous signs** of a signed bipartite graph  $G$  with equipollent vertex sets is defined to be  $m(G) = m(A)$ .

*Example 2.5.* Consider the following two graphs.

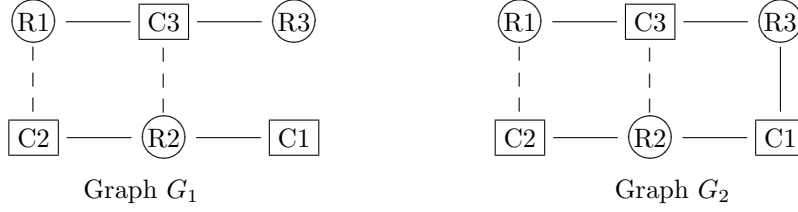

Graph  $G_1$  admits only one perfect matching  $\mathcal{W}$ . Namely the set of edges  $\{C1-R2, C2-R1, C3-R3\}$ . Hence its only cycle  $R1-C3-R2-C2-R1$  is not  $\mathcal{W}$ -interlacing. The sign pattern associated to  $G_1$  is

$$B = \begin{bmatrix} 0 & B_{12} & -B_{13} \\ -B_{21} & -B_{22} & B_{23} \\ 0 & 0 & -B_{33} \end{bmatrix}.$$

As  $\det(B) = -B_{12}B_{21}B_{33}$ ,  $m(G_1) = m(B) = 0$ .

Graph  $G_2$  on the other hand admits three perfect matchings. For instance, with respect to the matching  $\{C1-R3, C2-R2, C3-R1\}$ , the cycle  $R1-C3-R2-C2-R1$  is interlacing, while  $C1-R3-C3-R2-C1$  is not. The sign pattern associated to  $G_2$  is

$$C = \begin{bmatrix} 0 & C_{12} & -C_{13} \\ -C_{21} & -C_{22} & C_{23} \\ -C_{31} & 0 & -C_{33} \end{bmatrix}.$$

Since  $\det(C) = -C_{12}C_{23}C_{31} - C_{12}C_{21}C_{33} + C_{13}C_{22}C_{33}$ ,  $m(G_2) = m(C) = 1$ .

Note that the number of interlacing cycles depends on the matching chosen. For instance, the graph  $G_3$

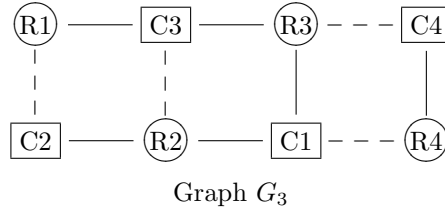

with the matching  $\{C1-R3, C2-R1, C3-R2, C4-R4\}$  admits three interlacing cycles, while it has four cycles interlacing with respect to the matching  $\{C1-R2, C2-R1, C3-R3, C4-R4\}$ . ■

The following theorem gives our *det sign test* counting the number of signs in the determinant expansion of a square sign pattern  $A$  in terms of  $G(A)$ . For the sake of simplicity it is stated for matrices with nonzero diagonal entries. This causes no loss of generality since such a matrix can be obtained from any square invertible matrix with a permutation of rows.

**Theorem 2.6.** *Let  $A$  be a square sign pattern with each diagonal element nonzero. Let  $\mathcal{W}$  be the perfect matching in the bipartite graph of  $A$  corresponding to its diagonal.*

- (1) *The number of terms,  $t(A)$ , in the determinant expansion of  $A$  is the number of disjoint  $\mathcal{W}$ -interlacing cycles of  $G(A)$ .*
- (2) *Let  $\epsilon$  be the sign of the product of the diagonal elements of  $A$ . Then the number of terms of sign  $-\epsilon$  in the determinant expansion of  $A$ ,  $m_{-\epsilon}(A)$ , equals the cardinality of the set of all sets of disjoint  $\mathcal{W}$ -interlacing cycles that contain an odd number of  $\mathcal{W}$ -interlacing  $e$ -cycles.*

*Remark 2.7.* By disjoint cycles we mean cycles with no common vertices. The empty set is counted as a set of cycles. ■

*Remark 2.8.* As observed in Example 2.5, the number of interlacing cycles depends on the matching  $\mathcal{W}$  chosen. However, the numbers  $t(A)$ ,  $m_{\pm}(A)$  and  $m(A)$  obtained from Theorem 2.6 are (clearly) independent of  $\mathcal{W}$ . ■

The special case of Theorem 2.6 where  $m(A) = 0$  is settled by [BS95, Theorem 3.2.1] which is due to Bassett, Maybee and Quirk [BMQ68].

The count of the signs in the determinant expansion is simple in extreme cases, as the following corollary shows. Recall [LMOD96] that a graph in which each pair of cycles has at least one vertex in common, is called an **intercyclic graph**.

**Corollary 2.9.** *Let  $A$  be a square sign pattern with each diagonal element nonzero. Let  $\mathcal{W}$  be the perfect matching in the bipartite graph of  $A$  corresponding to its diagonal. Let  $\epsilon$  denote the sign of the product of the diagonal elements of  $A$ .*

- (1) *Suppose that  $G(A)$  is an intercyclic graph with  $t$  cycles interlacing with respect to  $\mathcal{W}$ . Then the number of terms in the determinant expansion of  $A$  is  $1 + t$  and  $m_{-\epsilon}(A)$  is the number of  $\mathcal{W}$ -interlacing e-cycles.*
- (2) *Suppose that there are  $t \geq 1$  cycles of  $G(A)$  each of which is  $\mathcal{W}$ -interlacing and all are pairwise disjoint. Then the number of terms in the determinant expansion of  $A$  is  $2^t$  and the number of anomalous signs is either 0 (if all  $\mathcal{W}$ -interlacing cycles are o-cycles) or  $2^{t-1}$ . In the former case,  $m_{\epsilon} = 2^t$  and in the latter case  $m_{-}(A) = m_{+}(A) = 2^{t-1}$ .*

*Proof.* For (1) note that by assumption, every set of disjoint (interlacing) cycles of  $G(A)$  contains at most one cycle. (2) By Theorem 2.6.(1), the number of terms in the determinant expansion of  $A$  is just the number of all subsets of  $\{1, \dots, t\}$ , i.e.,  $2^t$ .

For the second part of the claim we will compute the number  $m_{-\epsilon}(A)$ . Let  $r$  be the number of e-cycles among the  $t$  interlacing cycles. Of course, if  $r = 0$ , then there will be no anomalous signs. So assume  $r > 0$ . There are  $t - r$  interlacing o-cycles. Since the cycles are pairwise disjoint, we have by Theorem 2.6 that a set consisting of some of the  $t$  interlacing cycles contributes a term with sign  $-\epsilon$  to the determinant expansion of  $A$  if and only if it contains an odd number of the  $r$  e-cycles. Thus to find  $m_{-\epsilon}(A)$  we multiply the number of ways we can choose an odd number of e-cycles from the  $r$  e-cycles by the number of ways we can choose any number of o-cycles from the  $t - r$  o-cycles. The number of ways we can choose an odd number of e-cycles from the  $r$  e-cycles is

$$\sum_{k=1}^{\lfloor \frac{r-1}{2} \rfloor} \binom{r}{2k+1}.$$

To simplify this, notice that  $0 = (-1 + 1)^r = \sum_{k=0}^r \binom{r}{k} (-1)^k$  implies

$$\sum_{k=1}^{\lfloor \frac{r-1}{2} \rfloor} \binom{r}{2k+1} = \frac{1}{2} \sum_{k=0}^r \binom{r}{k} = 2^{r-1}.$$

The number of ways we can choose a subset of o-cycles from the  $t - r$  o-cycles is  $2^{t-r}$ . Thus,  $m_{-\epsilon}(A) = 2^{r-1} \cdot 2^{t-r} = 2^{t-1}$  and hence  $m(A) = m_{\pm}(A) = 2^{t-1}$ . ■

*Example 2.10.* We now show how to determine when the determinant expansion of a square sign pattern  $A$  has no or one anomalous sign. Let us assume that all diagonal entries of  $A$  are nonzero and thus induce a perfect matching  $\mathcal{W}$ . By Theorem 2.6.(2),  $m(A) = 0$  if and only if  $G(A)$  contains no  $\mathcal{W}$ -interlacing e-cycles.

We claim that  $m(A) = 1$  if and only if  $G(A)$  contains exactly one  $\mathcal{W}$ -interlacing e-cycle and no  $\mathcal{W}$ -interlacing cycles disjoint from it. Clearly, ( $\Leftarrow$ ) follows from Theorem 2.6. For the converse, note that if  $G(A)$  contains at least two  $\mathcal{W}$ -interlacing e-cycles, then  $m(A) \geq 2$  by Theorem 2.6.(2). Similarly we exclude the possibility of only one  $\mathcal{W}$ -interlacing e-cycle with other  $\mathcal{W}$ -interlacing cycles disjoint from it. ■

**2.3.1. Proof of Theorem 2.6.** As preparation for the proof of the theorem, we briefly recall some well-known facts about  $S_n$ . A  $S_n$ -cycle  $s = (s_1 \cdots s_m)$  is the permutation mapping

$$s_1 \mapsto s_2 \mapsto \cdots \mapsto s_m \mapsto s_1$$

and fixing  $\{1, \dots, n\} \setminus \{s_1, \dots, s_m\}$  pointwise. To avoid collision with cycles in various graphs appearing in the paper, we call these cycles  $S_n$ -cycles.

*Example 2.11.* For instance, the  $S_4$ -cycle  $\sigma = (1\ 2\ 4)$  is the mapping

$$\left( \begin{array}{cccc} \overline{1} & \overline{2} & \overline{3} & \overline{4} \\ \downarrow & \downarrow & \downarrow & \downarrow \\ 2 & 4 & 3 & 1 \end{array} \right),$$

while the mapping

$$\left( \begin{array}{ccccccc} \overline{1} & \overline{2} & \overline{3} & \overline{4} & \overline{5} & \overline{6} & \overline{7} \\ \downarrow & \downarrow & \downarrow & \downarrow & \downarrow & \downarrow & \downarrow \\ 2 & 4 & 5 & 1 & 3 & 6 & 7 \end{array} \right)$$

can be written as  $(1\ 2\ 4)(3\ 5)$ . ■

Every permutation  $\sigma \in S_n$  can be written uniquely (up to the ordering in the product) as a product of disjoint  $S_n$ -cycles. Conversely, every set of disjoint  $S_n$ -cycles gives a permutation in  $S_n$ .

**Lemma 2.12.** *If  $\sigma = \tau_1 \cdots \tau_m$  is a factorization of  $\sigma \in S_n$  into disjoint  $S_n$ -cycles, and  $\tau_i = (\tau_{i1}\ \tau_{i2}\ \cdots\ \tau_{it_i})$ , then*

$$\text{sign}(\sigma) \prod_{i=1}^n A_{i,\sigma(i)} = \prod_{j=1}^m (-1)^{t_j-1} \prod_{i=1}^{t_j} A_{\tau_j i, \tau_j i+1} \prod_{k \notin \{\tau_{ij}\}} A_{k,k}$$

(with the convention  $\tau_j t_{j+1} = \tau_j 1$ ).

*Proof.* If  $\sigma$  contributes to the determinant, then every  $\tau_i$  induces a cycle of  $G(A)$ . For instance, the cycle  $G(\tau_i)$  corresponding to  $\tau_i$  is defined to be the subgraph

$$R(\tau_{i1}) - C(\tau_{i2}) - R(\tau_{i2}) - C(\tau_{i3}) - \cdots - R(\tau_{it_i}) - C(\tau_{i1}) - R(\tau_{i1})$$

of  $G(A)$ . The other ingredient is  $\text{sign}(\sigma) = \text{sign}(\tau_1) \cdots \text{sign}(\tau_m)$  and  $\text{sign}(\tau_i) = (-1)^{t_i-1}$ . ■

*Proof of Theorem 2.6.* Let  $A$  be  $n \times n$ . Statement (1) follows from Remark 2.2. To see why (2) is true, we invoke the determinant expansion formula (2.1). For convenience we assume that all diagonal entries of  $A$  are negative. Then  $\epsilon = (-1)^n$  and we count the number of terms with sign  $-\epsilon$ . Each term  $x = \text{sign}(\sigma) \prod_{i=1}^n A_{i,\sigma(i)}$  in the expansion gives us a permutation  $\sigma \in S_n$ . Since every permutation can be written uniquely as a product of disjoint  $S_n$ -cycles, we obtain a set of disjoint cycles  $\tau_1, \dots, \tau_\ell$  with  $\sigma = \tau_1 \cdots \tau_\ell$ . Say  $\tau_i = (\tau_{i1}\ \tau_{i2}\ \cdots\ \tau_{it_i})$ . By the previous lemma,

$$x = \prod_{j=1}^{\ell} (-1)^{t_j-1} \prod_{i=1}^{t_j} A_{\tau_j i, \tau_j i+1} \prod_{k \notin \{\tau_{ij}\}} A_{k,k}.$$

Observe that the sign of a product of the form  $\prod_{i=1}^{t_j} A_{\tau_j i, \tau_j i+1}$  equals

$$(-1)^{\text{number of c-pairs in } G(\tau_i)} =: \text{sign}(G(\tau_i)).$$

Taking into account that all diagonal entries are negative, the sign of  $x$  then equals the sign of

$$(-1)^{\sum_{i=1}^{\ell} (t_i-1)} (-1)^{n - \sum_{i=1}^{\ell} t_i} \prod_{i=1}^{\ell} \text{sign}(G(\tau_i)).$$

This simplifies further to

$$(-1)^{n-\ell} \prod_{i=1}^{\ell} \text{sign}(G(\tau_i)).$$

In order for the term  $x$  to have sign  $(-1)^{n-1}$ ,  $(-1)^{\ell} \prod_{i=1}^{\ell} \text{sign}(G(\tau_i))$  must not be equal 1. We will show this is the case if and only if the number of e-cycles among  $\tau_0, \dots, \tau_\ell$  is odd.

Case (1): Suppose  $\ell$  is odd. Then

$$\begin{aligned} (-1)^\ell \prod_{i=1}^{\ell} \text{sign}(G(\tau_i)) = -1 &\iff \prod_{i=1}^{\ell} \text{sign}(G(\tau_i)) = 1 \\ &\iff (-1)^{\#(\text{o-cycles among } \tau_0, \dots, \tau_\ell)} = 1 \\ &\iff \#(\text{o-cycles among } \tau_0, \dots, \tau_\ell) \text{ is even} \\ &\iff \#(\text{e-cycles among } \tau_0, \dots, \tau_\ell) \text{ is odd,} \end{aligned}$$

since  $\ell$  is odd and  $\#(\text{e-cycles}) = \ell - \#(\text{o-cycles})$ .

Case (2): Suppose  $\ell$  is even. Then

$$\begin{aligned} (-1)^\ell \prod_{i=1}^{\ell} \text{sign}(G(\tau_i)) = -1 &\iff \prod_{i=1}^{\ell} \text{sign}(G(\tau_i)) = -1 \\ &\iff (-1)^{\#(\text{o-cycles among } \tau_0, \dots, \tau_\ell)} = -1 \\ &\iff \#(\text{o-cycles among } \tau_0, \dots, \tau_\ell) \text{ is odd} \\ &\iff \#(\text{e-cycles among } \tau_0, \dots, \tau_\ell) \text{ is odd,} \end{aligned}$$

since  $\ell$  is even and  $\#(\text{e-cycles}) = \ell - \#(\text{o-cycles})$ . ■

A referee has pointed out that this proof is along the lines of a refinement of the [BMQ68] proof.

**2.4. Many Cycles: Nonsquare Matrices.** The graph-theoretic test described in §2.3 gives a det sign test settling Question (J-sign). In this section we extend the det sign test to nonsquare sign patterns  $S$ .

A cycle has the property that the number of rows it passes through is the same as the number of columns it passes through. A set of cycles is called **balanced** if the number of rows they pass through is the same as the number of columns they pass through (i.e., if they are incident with the same number of rows and columns). Every balanced set of cycles picks out a square submatrix  $A$  of  $S$  and hence induces a sub-bipartite graph  $G(A)$  of  $G(S)$ . Such a submatrix and the sub-bipartite graph are both said to be **balanced**. Note each column and row of  $A$  appears in at least one cycle in  $G(A)$ .

**Proposition 2.13.** *For every square invertible submatrix  $B$  of a sign pattern  $S$  there is a balanced square submatrix  $A$  of  $S$  with  $m(A) = m(B)$ . In fact,  $A$  can be chosen to be a submatrix of  $B$ .*

*Proof.* Suppose  $B$  is the smallest square submatrix of  $S$  violating the conclusion of the proposition. After permuting rows we assume  $B$  has nonzero entries on the diagonal. Since  $B$  is not balanced, either a row or a column of  $B$  does not appear in any cycle in  $G(B)$ . Without loss of generality we assume this to be row 1.

Since we assume that row 1 does not appear in any cycle of  $G(B)$ , for  $\sigma \in S_n$  with  $\sigma = \tau_1 \cdots \tau_\ell$ , where  $\tau_i$  are disjoint  $S_n$ -cycles, the corresponding term in the determinant expansion  $x = \text{sign}(\sigma) \prod_{i=1}^n B_{i, \sigma(i)}$  will be zero if 1 appears in one of the  $\tau_i$ . Hence the nonzero terms  $x$  will correspond to permutations  $\sigma$  with  $\sigma(1) = 1$ . In other words,  $B_{1,1}$  will get picked from row one. So by removing row and column one from  $B$  we obtain a smaller matrix  $B_0$  with  $m(B_0) = m(B)$ . By the minimality assumption on  $B$ , there is a balanced square submatrix  $A$  of  $B_0$  with  $m(A) = m(B_0) = m(B)$ , a contradiction. ■

By this proposition, *the answer  $J$  to Question (J-sign) equals the maximal number of anomalous signs obtainable from a balanced square submatrix of the sign pattern  $S$* . So a procedure for finding the desired upper bound  $J$  is as follows. Consider sets of balanced cycles in  $G(S)$ . Each of these induces a square submatrix  $A$  of  $S$ . If  $G(A)$  admits no perfect matching, we continue with another set of balanced cycles. Otherwise we count the number of anomalous signs in  $\det A$  by the procedure described in Theorem 2.6 of §2.3. The highest possible count obtained is the desired sharp upper bound  $J$ .



## 3. REACTION FORM DIFFERENTIAL EQUATIONS AND THE JACOBIANS

Now we turn to studying systems of reaction form (RF) ordinary differential equations which act on the nonnegative orthant  $\mathbb{R}_{\geq 0}^d$  in  $\mathbb{R}^d$ :

$$(3.1) \quad \frac{dx}{dt} = f(x) = Sv(x),$$

where  $f : \mathbb{R}_{\geq 0}^d \rightarrow \mathbb{R}^d$ ,  $S$  is a real  $d \times d'$  matrix and  $v$  is a column vector consisting of  $d'$  real-valued functions.

The differential equation (3.1) has **weak reaction form** (wRF) provided  $V(x) := v'(x)$  satisfies  $S_{ij} > 0 \Rightarrow V_{ji}(x) = 0$ . If a differential equation has wRF, then it has reaction form provided  $S_{ij} = 0 \Rightarrow V_{ji}(x) = 0$  and  $S_{ij} < 0 \Rightarrow V_{ji}(x) \neq 0$ . The flux vector  $v(x)$  is **monotone nondecreasing** (respectively, **monotone increasing**) if  $\frac{\partial v_i}{\partial x_i}(x)$  is either 0 for all  $x \in \mathbb{R}_{\geq 0}^{d'}$  or nonnegative (respectively, positive) for all  $x \in \mathbb{R}_{> 0}^{d'}$ .

This section analyzes two properties the Jacobian of  $f(x)$  might have. First we say when  $f'(x)$  has a sign pattern (Theorem 3.2 and Corollary 3.1). Secondly we give a method based on §2 for counting the number of plus and minus coefficients in its determinant expansion.

**3.1. Sign pattern of the Jacobian.** We first say when the Jacobian of a reaction form dynamics respects a sign pattern and find that it does surprisingly often.

**Corollary 3.1.** *Given a reaction form differential equation*

$$\frac{dx}{dt} = Sv(x)$$

*with monotone increasing flux vector  $v(x)$ . The Jacobian  $Sv'(x)$  respects the same sign pattern for all  $x \in \mathbb{R}_{> 0}^n$  if the bipartite graph  $G(S)$  does not contain a cycle of length four with three negative edges.*

The corollary is an immediate consequence of Theorem 3.2.(3) which is phrased symbolically. Note that while the cycle condition is a necessary condition in Corollary 3.1, it is both necessary and sufficient in Theorem 3.1.(3). We now introduce some definitions required to formulate our sign pattern results symbolically.

Here and in the sequel,  $U$  will denote what we call the **flux pattern** assigned to  $S$ . It is defined to be a  $d' \times d$  matrix with each entry being 0 or a free variable  $U_{ij}$ ; the  $(i, j)$ th entry of  $U$  is 0 if and only if  $S_{ji} \geq 0$ . In case the differential equation (3.1) satisfies RF and the flux vector  $v(x)$  is monotone increasing,  $U$  is the sign pattern of  $V(x)$ . For an illustration, see Example 3.5.

**Theorem 3.2.** *Let  $S$  be a real  $d \times d'$  matrix and  $U$  the corresponding flux pattern. Consider (3.1) and suppose that the  $V_{ij}(x)$  for fixed  $i$  are linearly independent. Then:*

- (1) *The differential equation (3.1) has wRF if and only if each diagonal term in  $SV(x)$  is a negative linear combination of the  $V_{ij}(x)$ .*
- (2) *(Weak reaction form differential equations) If (3.1) has wRF, then  $SV(x)$  admits a sign pattern (that is, each entry of  $SV(x)$  is a positive or negative linear combination of monomials in the  $V_{ij}(x)$ ) whenever the matrix  $S$  does not contain a  $2 \times 2$  submatrix with the same sign pattern as*

$$(3.2) \quad \begin{bmatrix} +1 & -1 \\ -1,0 & -1,0 \end{bmatrix} \quad \text{or} \quad \begin{bmatrix} -1 & +1 \\ -1,0 & -1,0 \end{bmatrix} \quad \text{or} \quad \begin{bmatrix} -1,0 & -1,0 \\ +1 & -1 \end{bmatrix} \quad \text{or} \quad \begin{bmatrix} -1,0 & -1,0 \\ -1 & +1 \end{bmatrix}.$$

Here  $-1,0$  stands for either  $-1$  or  $0$ .

- (3) *(Reaction form differential equations)*
  - (a) *The product  $SU$  admits a sign pattern if and only if the matrix  $S$  does not contain a  $2 \times 2$  submatrix with the same sign pattern as*

$$(3.3) \quad \begin{bmatrix} +1 & -1 \\ -1 & -1 \end{bmatrix} \quad \text{or} \quad \begin{bmatrix} -1 & +1 \\ -1 & -1 \end{bmatrix} \quad \text{or} \quad \begin{bmatrix} -1 & -1 \\ +1 & -1 \end{bmatrix} \quad \text{or} \quad \begin{bmatrix} -1 & -1 \\ -1 & +1 \end{bmatrix}.$$

*Equivalently, in terms of the bipartite graph,  $G(S)$  does not contain a cycle of length four with three negative edges.*

- (b) *The entry  $(SU)_{ij}$  is nonzero if and only if there is some  $k$  with  $S_{ik} \neq 0$  and  $S_{jk} < 0$ . If  $SU$  admits a sign pattern, then  $\text{sign}((SU)_{ij}) = \text{sign}(S_{ik})$ .*

*Proof.* (1) Write  $S = S_+ - S_-$  for real matrices  $S_+, S_-$  with nonnegative coefficients satisfying the complementarity property  $(S_+)_{ij}(S_-)_{ij} = 0$ . Diagonal entries of  $SV(x)$  are of the form  $\sum_j S_{ij}V_{ji}(x)$  which meets the negative coefficient condition if and only if  $\sum_j (S_+)_{ij}V_{ji}(x) = 0$  if and only if  $(S_+)_{ij}V_{ji}(x) = 0$  for all  $i, j$ . This uses the linear independence of the  $V_{ji}(x)$ , so no cancellation can occur. Thus  $S_{ij} > 0$  if and only if  $(S_+)_{ij} \neq 0$  implies  $V_{ji}(x) = 0$  which is the wRF condition.

(2) The  $(i, j)$ th entry of  $SV(x)$  does not have a sign pattern if and only if  $(S_+V(x))_{ij} \neq 0$  and  $(S_-V(x))_{ij} \neq 0$ .  $(S_+V(x))_{ij} = \sum_k (S_+)_{ik}V_{kj}(x)$ , so  $(S_+V(x))_{ij} \neq 0$  if and only if for some  $k$ ,  $S_{ik} > 0$  and  $V_{kj}(x) \neq 0$ , so by wRF,  $S_{jk} \not\geq 0$ . To summarize:  $S_{ik} > 0$  and  $S_{jk} \not\geq 0$ . Similarly,  $(S_-V(x))_{ij} \neq 0$  if and only if there is some  $\ell$  with  $(S_-)_{i\ell} \neq 0$  and  $V_{\ell j}(x) \neq 0$  so  $S_{j\ell} \not\geq 0$ . In summary,  $S_{i\ell} < 0$  and  $S_{j\ell} \not\geq 0$ . Taken together this implies that the  $2 \times 2$  submatrix of  $S$  given by rows  $i, j$  and columns  $k, \ell$  has the same sign pattern as one of the matrices in (3.2).

(3a) This follows as in (2) by using that  $U_{kj} \neq 0$  if and only if  $S_{jk} < 0$ .

(3b) From  $(SU)_{ij} = \sum_k S_{ik}U_{kj}$  it follows that  $(SU)_{ij} \neq 0$  if and only if there is  $k$  with  $S_{ik} \neq 0$  and  $U_{kj} \neq 0$ . Due to the construction of  $U$ ,  $U_{kj} \neq 0$  if and only if  $S_{jk} < 0$ . This proves the first part of the statement and the second follows immediately since  $U_{kj}$  is “positive”. ■

The issue in Theorem 3.2 is a variant on a simple characterization of when the product  $AB$  of two sign patterns  $A$  and  $B$ , having “transposed” sign patterns, has a sign pattern, cf. §5.

Our next step is to introduce several different types of determinant expansions.

**3.2. The core and other determinant expansions.** Now we change to the topic of determinant expansions of the Jacobian of  $f$ . Such were introduced to the subject of chemical reaction networks in [CF05] and are discussed in §1.3 and §4. The **Craciun-Feinberg determinant expansion** [CF05] is defined to be

$$\text{cfd}(S) := \det(SU - \tau I) \text{ with } \tau \text{ fixed, e.g. } \tau = 1$$

for  $S \in \mathbb{R}^{d \times d'}$  and the corresponding flux pattern  $U$ . In this paper we introduce and study the **core determinant**

$$(3.4) \quad \text{cd}(S) := \lim_{\tau \rightarrow 0} \frac{1}{\tau^{d-r}} \det(SU - \tau I),$$

where  $r := \text{rank}(S)$ . It is appropriate for analysis of many chemical reaction networks, see Theorem 4.1. For more details on the relationship between the Craciun-Feinberg determinant expansion  $\text{cfd}(S)$  and the core determinant  $\text{cd}(S)$  we refer the reader to §4.

The remainder of this section sets up machinery for the study of determinant expansions. We devote most of our attention to the core determinant, because our ideas when applied to the Craciun-Feinberg determinant are very similar. §3.2, §3.3 and §3.4 introduce definitions and constructions, then §3.5, §3.6 and §3.7 give bounds on the number of anomalous signs as well as examples.

**Proposition 3.3.** *Let  $C \in \mathbb{R}^{d \times d'}$ , let  $D$  be a  $d' \times d$  matrix with possibly symbolic entries and suppose  $C$  has rank  $r$ . Define  $\alpha$  to be the determinant of the compression of  $CD$  to the range of  $C$ . Then*

$$\alpha = \lim_{\tau \rightarrow 0} \frac{1}{\tau^{d-r}} \det(CD - \tau I).$$

*Proof.* Observe that

$$CD - \tau I = \begin{bmatrix} (CD - \tau I)|_{\text{im } C} & * \\ 0 & -\tau I|_{(\text{im } C)^\perp} \end{bmatrix}.$$

As the size of the second diagonal block is  $(d-r) \times (d-r)$ ,

$$\frac{1}{\tau^{d-r}} \det(CD - \tau I) = \det((CD - \tau I)|_{\text{im } C}).$$

Sending  $\tau \rightarrow 0$  yields the desired conclusion. ■

**Definition 3.4.** A column  $c$  in  $S \in \mathbb{R}^{d \times d'}$  is called **reversible** if  $-c$  is also a column of  $S$ . (Many matrices coming from chemical reactions have reversible columns.) We call  $-c$  the **reverse** of  $c$ .

*Example 3.5.* Let us consider an example which is a slight modification of [CF05, Table 1.1.(i)]:

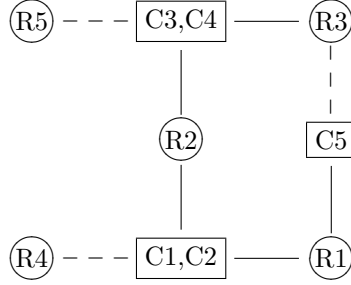

The corresponding stoichiometric matrix  $S$  and the vector  $v(x)$  are given by the following:

$$S = \begin{bmatrix} a_{11} & -a_{11} & 0 & 0 & -a_{13} \\ a_{21} & -a_{21} & a_{22} & -a_{22} & 0 \\ 0 & 0 & a_{32} & -a_{32} & a_{33} \\ -a_{41} & a_{41} & 0 & 0 & 0 \\ 0 & 0 & -a_{52} & a_{52} & 0 \end{bmatrix}, \quad v(x) = \begin{bmatrix} k_1 x_4^{a_{41}} \\ k_2 x_1^{a_{11}} x_2^{a_{21}} \\ k_3 x_5^{a_{52}} \\ k_4 x_2^{a_{22}} x_3^{a_{32}} \\ k_5 x_1^{a_{13}} \end{bmatrix}.$$

Note some of the columns of  $S$  are reversible. This phenomenon is captured in the graph by listing two columns that are reverses of each other in a common rectangular box. For example, C3 and C4 appear in the same box and in fact columns 3 and 4 are reverses of each other. The sign of  $S_{33}$  is the same as the sign of  $S_{23}$  and both appear in the graph as a solid line.  $S_{53}$  has sign opposite to these and so appears in the graph as a dashed line. This is also true for C4. Other dashed vs. solid lines of the graph coming from a box with reversible columns follow the same pattern.

The corresponding  $V(x)$  and  $U$  are as follows:

$$V(x) = \begin{bmatrix} 0 & 0 & 0 & x_4^{a_{41}-1} a_{41} k_1 & 0 \\ x_1^{a_{11}-1} x_2^{a_{21}} a_{11} k_2 & x_1^{a_{11}} x_2^{a_{21}-1} a_{21} k_2 & 0 & 0 & 0 \\ 0 & 0 & 0 & 0 & x_5^{a_{52}-1} a_{52} k_3 \\ 0 & x_2^{a_{22}-1} x_3^{a_{32}} a_{22} k_4 & x_2^{a_{22}} x_3^{a_{32}-1} a_{32} k_4 & 0 & 0 \\ x_1^{a_{13}-1} a_{13} k_5 & 0 & 0 & 0 & 0 \end{bmatrix},$$

$$U = \begin{bmatrix} 0 & 0 & 0 & U_{14} & 0 \\ U_{21} & U_{22} & 0 & 0 & 0 \\ 0 & 0 & 0 & 0 & U_{35} \\ 0 & U_{42} & U_{43} & 0 & 0 \\ U_{51} & 0 & 0 & 0 & 0 \end{bmatrix}.$$

For generic choices of the numbers  $a_{ij}$  the matrix  $S$  will be of rank 3 and this is what we focus on. A straightforward computation gives

$$\begin{aligned} \text{cd}(S) &= -2a_{13}a_{41}a_{52}U_{14}U_{35}U_{51} - 2a_{13}a_{21}a_{52}U_{22}U_{35}U_{51} - 2a_{13}a_{22}a_{41}U_{14}U_{42}U_{51} \\ &\quad - 2a_{13}a_{32}a_{41}U_{14}U_{43}U_{51} - 2a_{13}a_{21}a_{32}U_{22}U_{43}U_{51} + 2a_{11}a_{22}a_{33}U_{22}U_{43}U_{51} \end{aligned}$$

Hence there is potentially one anomalous sign in  $\text{cd}(S)$ . However,

$$-2a_{13}a_{21}a_{32}U_{22}U_{43}U_{51} + 2a_{11}a_{22}a_{33}U_{22}U_{43}U_{51} = 2(a_{11}a_{22}a_{33} - a_{13}a_{21}a_{32})U_{22}U_{43}U_{51}$$

so  $\text{cd}(S)$  has one, respectively no anomalous sign, depending on whether  $a_{11}a_{22}a_{33} - a_{13}a_{21}a_{32}$  is positive, respectively nonpositive. ■

*Example 3.6.* Suppose  $S = \begin{bmatrix} -a_{11} & a_{11} \\ -a_{21} & a_{21} \end{bmatrix}$ . Then  $SU - I$  admits a sign pattern; it is a  $2 \times 2$  matrix with all entries negative. Hence the determinant expansion of its sign pattern has one anomalous sign by the det sign test. However,  $\text{cfd}(S)$  and  $\text{cd}(S)$  have no anomalous signs. ■

**3.3. Formulas for determinants of products of matrices.** For a matrix  $A$ ,  $A[\alpha, \delta]$  will refer to the submatrix of  $A$  with rows indexed by  $\alpha$  and columns indexed by  $\delta$ . If  $\alpha$  is the full set of rows, we shall simply write  $A[:, \delta]$  etc.

Recall the **Binet-Cauchy formula** for the determinant of the product  $AB$  of a  $m \times n$  matrix  $A$  and a  $n \times m$  matrix  $B$ :

$$(3.5) \quad \det(AB) = \sum_{\substack{\delta \subseteq \{1, \dots, n\} \\ |\delta| = m}} \det(A[:, \delta]) \det(B[\delta, :]).$$

(If  $m > n$ , then there is no admissible set  $\delta$  and the determinant  $\det(AB)$  is zero.)

Combining Proposition 3.3 with the Binet-Cauchy formula we obtain

**Lemma 3.7.** *For  $S \in \mathbb{R}^{d \times d'}$  having rank  $r$ , the core determinant is given by*

$$(3.6) \quad \text{cd}(S) = (-1)^{d-r} \sum_{|\alpha|, |\beta| = r} \det(S[\alpha, \beta]) \det(U[\beta, \alpha]).$$

*Proof.* Use (3.5) and  $PQ + GH = \begin{bmatrix} P & G \end{bmatrix} \begin{bmatrix} Q \\ H \end{bmatrix}$  to get

$$(3.7) \quad \det(SU - \tau I) = \sum_{|\delta| = d} \det\left(\begin{bmatrix} S & -\tau I \end{bmatrix}[:, \delta]\right) \det\left(\begin{bmatrix} U \\ I \end{bmatrix}[\delta, :]\right),$$

where  $d$  is the number of rows of  $S$ . Since rank  $S$  is  $r$ ,  $\tau^{d-r}$  factors out of  $\det\left(\begin{bmatrix} S & -\tau I \end{bmatrix}[:, \delta]\right)$ , so  $\lim_{\tau \rightarrow 0} \frac{1}{\tau^{d-r}} \det\left(\begin{bmatrix} S & -\tau I \end{bmatrix}[:, \delta]\right)$  exists. Let us look at terms of degree  $d-r$  in  $\tau$  in (3.7). The determinant  $\det\left(\begin{bmatrix} S & -\tau I \end{bmatrix}[:, \delta]\right)$  will be of degree  $d-r$  in  $\tau$  if and only if  $\delta$  will consists of exactly  $r$  columns  $\beta$  of  $S$ . If  $\alpha$  denotes the set of rows of  $S$  that do not hit any of the columns of  $-\tau I$  chosen by  $\beta$ , then

$$\det\left(\begin{bmatrix} S & -\tau I \end{bmatrix}[:, \delta]\right) = (-1)^{d-r} \tau^{d-r} \det(S[\alpha, \beta]).$$

It is clear that such pairs  $(\alpha, \beta)$  are in a bijective correspondence with all  $\delta$  that pick  $r$  columns of  $S$ . Hence

$$\det(SU - \tau I) = (-\tau)^{d-r} \sum_{|\alpha|, |\beta| = r} \det(S[\alpha, \beta]) \det(U[\beta, \alpha]) + (\text{higher order terms in } \tau).$$

Dividing by  $\tau^{d-r}$  and sending  $\tau \rightarrow 0$  proves (3.6). ■

Formulas (3.6) and (3.7) are in contrast to  $\text{cfd}(S)$  which is given by the more complicated expression

$$(3.8) \quad \text{cfd}(S) = \sum_{s=1}^r \sum_{|\alpha|=|\beta|=s} (-\tau)^{d-s} \det(S[\alpha, \beta]) \det(U[\beta, \alpha])$$

The fact is known (cf. [CF05], [BDB07, proof of Theorem 4.4]) and its proof follows the line of the proof of Lemma 3.7.

For the chemical interpretation of the core determinant vs. the Craciun-Feinberg determinant see our §4.

**Lemma 3.8.** *The number of anomalous signs in  $\text{cd}(S)$  is at most the number of anomalous signs in  $\text{cfd}(S)$ .*

*Proof.* By looking at the formulas (3.6) and (3.8) it is clear that each term appearing in  $\text{cd}(S)$  also appears (multiplied with  $\tau^{d-r}$ ) in  $\text{cfd}(S)$ . Terms coming from  $\text{cd}(S)$  have degree  $r$  in the  $U_{ij}$ 's, while all terms in  $\text{cfd}(S)$  not coming from terms in  $\text{cd}(S)$  have degree  $< r$  in the  $U_{ij}$ 's. Thus there is no cancellation and the statement follows. ■

*Remark 3.9.* Example 3.21 shows that the number of anomalous signs in  $\text{cd}(S)$  can be strictly smaller than the number of anomalous signs in  $\text{cfd}(S)$ .

If  $B$  is the sign pattern associated to the graph  $G_1$  of Example 2.5, and  $S = \begin{bmatrix} B & -B \end{bmatrix}$ , then  $\text{cd}(S)$  has no anomalous signs, whereas  $\text{cfd}(S)$  has one anomalous sign. We leave this as an exercise for the interested reader. ■

**3.4. Generic matrices and the reduced  $S$ -matrix.** In this section we introduce some basic definitions and illustrate them with an example.

**Definition 3.10.** A matrix  $A$  is called **weakly generic** if its rank  $r$  is maximal among all matrices with the same sign pattern. If, in addition, all  $r \times r$  submatrices of  $A$  are weakly generic, then  $A$  is called **generic**.

The set of all (weakly) generic  $m \times m$  matrices with a given sign pattern is open and dense in the set of all  $m \times m$  matrices with that sign pattern.

**Lemma 3.11.** *The rank  $r$  of a generic matrix  $A$  with connected graph  $G(A)$  is equal to the minimum of the number of rows or of columns of  $A$ . If  $G(A)$  has  $\ell$  components  $G_1, \dots, G_\ell$  and  $r_i$  is the minimal number of column or row nodes in  $G_i$ , then  $r = \sum_{i=1}^{\ell} r_i$ .*

*Proof.* Obvious. ■

**Definition 3.12.** For  $S \in \mathbb{R}^{d \times d'}$  let  $S_{\text{red}}$  denote a **reduced  $S$ -matrix**, i.e., a matrix obtained from  $S$  by removing one column out of every pair of columns which are reverses of each other. Clearly,  $S_{\text{red}}$  contains no reversible columns. The **reduced flux pattern**  $U_{\text{red}}$  is obtained from  $S$  and  $S_{\text{red}}$ : it is built from the sign pattern of  $-S_{\text{red}}^T$  by setting all entries coming from positive entries in columns nonreversible in  $S$  to 0. In particular, if all columns of  $S$  are reversible, then  $U_{\text{red}}$  is the sign pattern of  $-S_{\text{red}}^T$ . If no column of  $S$  is reversible, then  $S_{\text{red}} = S$  and  $U_{\text{red}} = U$ .

*Example 3.13.* Let us revisit Example 3.5. A reduced  $S$ -matrix  $S_{\text{red}}$  and the reduced flux pattern  $U_{\text{red}}$  are

$$S_{\text{red}} = \begin{bmatrix} a_{11} & 0 & -a_{13} \\ a_{21} & a_{22} & 0 \\ 0 & a_{32} & a_{33} \\ -a_{41} & 0 & 0 \\ 0 & -a_{52} & 0 \end{bmatrix}, \quad U_{\text{red}} = \begin{bmatrix} -U_{11} & -U_{12} & 0 & U_{14} & 0 \\ 0 & -U_{22} & -U_{23} & 0 & U_{25} \\ U_{31} & 0 & 0 & 0 & 0 \end{bmatrix}.$$

In most cases  $S_{\text{red}}$  will be generic and hence of rank 3. By a straightforward computation,

$$S_{\text{red}}U_{\text{red}} = \begin{bmatrix} -a_{11}U_{11} - a_{13}U_{31} & -a_{11}U_{12} & 0 & a_{11}U_{14} & 0 \\ -a_{21}U_{11} & -a_{21}U_{12} - a_{22}U_{22} & -a_{22}U_{23} & a_{21}U_{14} & a_{22}U_{25} \\ a_{33}U_{31} & -a_{32}U_{22} & -a_{32}U_{23} & 0 & a_{32}U_{25} \\ a_{41}U_{11} & a_{41}U_{21} & 0 & -a_{41}U_{14} & 0 \\ 0 & a_{52}U_{22} & a_{52}U_{23} & 0 & -a_{52}U_{25} \end{bmatrix}$$

After a possible renaming of the free variables in  $U_{\text{red}}$ ,  $SU = S_{\text{red}}U_{\text{red}}$ . This is the *key observation* we use in the next sections in order to count or estimate the number of anomalous signs in  $\text{cd}(S)$ . ■

**Lemma 3.14.** *If  $S$  is a real  $d \times d'$  matrix, if  $S_{\text{red}}$  is any reduced  $S$ -matrix and  $U_{\text{red}}$  the corresponding reduced flux pattern, then*

$$SU = S_{\text{red}}U_{\text{red}}$$

*after a possible renaming of the free variables in  $U_{\text{red}}$ .*

*Proof.* Suppose first that  $S = \begin{bmatrix} S_{\text{red}} & -S_{\text{red}} \end{bmatrix}$ . The corresponding matrix  $U$  is of the form

$$(3.9) \quad U = \begin{bmatrix} U_0 \\ U_1 \end{bmatrix}.$$

The sign pattern of  $U_0^T$  is the same as that of  $-S_{\text{red}}$ . Furthermore, nonzero entries of  $U_0^T$  coincide with negative entries of  $S_{\text{red}}$ . Similarly, nonzero entries of  $U_1^T$  coincide with positive entries of  $S_{\text{red}}$ .

Clearly,  $SU = S_{\text{red}}(U_0 - U_1) = S_{\text{red}}U_{\text{red}}$  (after a possible renaming of the free variables in  $U_{\text{red}}$ ).

Let us now look at the general case, where some of the columns do not have reverses in  $S$ . We ‘expand’  $S$  to  $\tilde{S} = \begin{bmatrix} S_{\text{red}} & -S_{\text{red}} \end{bmatrix}$  by adding reverses of nonreversible columns. We insert rows of zeros at the appropriate places in  $U$ . Again, we write

$$\tilde{U} = \begin{bmatrix} U_0 \\ U_1 \end{bmatrix}.$$

As before, nonzero entries of  $U_0^T$  correspond to negative entries of  $S_{\text{red}}$ . (Nonzero entries of  $U_1^T$  correspond to a subset of the set of all positive entries of  $S_{\text{red}}$ .) As  $U_0 - U_1 = U_{\text{red}}$ , this concludes the proof. ■

**3.5. Counting anomalous signs when  $S_{\text{red}}$  is square.** Now we give our main theorem for square reduced  $S$ -matrices. The result is strong and effectively reduces the problem to the matrix and graph-theoretic test of §2.4.

**Theorem 3.15.** *Let  $S$  be a real  $d \times d'$  matrix and suppose  $S_{\text{red}}$  is a generic square invertible matrix. Then:*

- (1) *The number of terms in the core determinant  $\text{cd}(S)$  equals the number of terms in the determinant expansion of  $U_{\text{red}}$ .*
- (2) *The number of anomalous signs of the core determinant  $\text{cd}(S)$  is the number of anomalous signs in the determinant expansion of  $U_{\text{red}}$ .*

*Remark 3.16.* Note that the theorem gives a count of positive and negative terms in  $\text{cd}(S)$  when combined with Theorem 2.6. The number of (anomalous) signs in the determinant expansion of  $U_{\text{red}}$  is bounded above by the number of (anomalous) signs in the determinant expansion of the sign pattern of  $S_{\text{red}}$ . ■

*Proof of Theorem 3.15.* Follows immediately from Lemma 3.14. ■

**3.6. Rectangular  $S_{\text{red}}$  matrices.** This section gives results and examples for the case of rectangular reduced  $S$ -matrices. Our theorem for complicated situations would not easily yield the precise count. On the other hand, it yields estimates and in various simple cases it is effective.

We can use Lemma 3.14 to provide a Binet-Cauchy expansion with fewer terms than there were in Lemma 3.7, namely:

**Lemma 3.17.** *For  $S \in \mathbb{R}^{d \times d'}$  having rank  $r$ , the core determinant is given by*

$$(3.10) \quad \text{cd}(S) = (-1)^{d-r} \sum_{|\alpha|, |\beta|=r} \det(S_{\text{red}}[\alpha, \beta]) \det(U_{\text{red}}[\beta, \alpha]).$$

Theorem 3.15 and Remark 3.16 tell us how to count the number of positive, negative or anomalous signs in  $\text{cd}(S)$  with generic  $S_{\text{red}}$ . By the Binet-Cauchy formula (3.10) given in Lemma 3.17 we count the number of positive and negative terms for each of the  $\det(U_{\text{red}}[\beta, \alpha])$  and take into account the sign of  $\det(S_{\text{red}}[\alpha, \beta])$ . The sum of these will give us a count for the number of positive and negative terms in  $\text{cd}(S)$ . Note: due to the freeness of entries of  $U$ , there is no cancellation between the summands. In particular, this count gives us a lower bound and upper bound on the number of anomalous signs in  $\text{cd}(S)$ .

**Theorem 3.18.** *Suppose  $S \in \mathbb{R}^{d \times d'}$  has rank  $r$ . Let  $S_{\text{red}}$  be a reduced  $S$ -matrix and  $U_{\text{red}}$  the reduced flux pattern. Suppose that  $S_{\text{red}}$  is generic.*

- (1) *The number of anomalous signs in  $\text{cd}(S)$  is at least*

$$\sum_{|\alpha|, |\beta|=r} m(U_{\text{red}}[\beta, \alpha])$$

*and at most*

$$\sum_{|\alpha|, |\beta|=r} t(U_{\text{red}}[\beta, \alpha]) - m(U_{\text{red}}[\beta, \alpha]).$$

(2) The number of terms of sign  $(-1)^{d-1}$  in  $\text{cd}(S)$  is at least

$$\sum_{S_{\text{red}}[\alpha, \beta] \in \mathcal{N}} m(U_{\text{red}}[\beta, \alpha])$$

and at most

$$\sum_{S_{\text{red}}[\alpha, \beta] \in \mathcal{N}} t(U_{\text{red}}[\beta, \alpha]) - m(U_{\text{red}}[\beta, \alpha]),$$

where  $\mathcal{N}$  is the set of all  $r \times r$  submatrices of  $S_{\text{red}}$  that are not SD.

*Proof.* (1) follows from the explanation given before the statement of the theorem, so we consider (2). For a SD matrix  $S_0 = S_{\text{red}}[\alpha, \beta]$ , all terms in the determinant expansion of the sign pattern of  $S_0$  have the same sign. Hence the same holds true for  $U_0 = U_{\text{red}}[\beta, \alpha]$  which is the sign pattern of  $-S_0^T$  with possibly some entries set to 0. If  $|\alpha| = |\beta| = r$ , then the sign of  $\det(U_0)$  is 0 or  $(-1)^r$  times the sign of  $\det(S_0)$ . Hence by Lemma 3.17, a term of sign  $(-1)^{d-1}$  in  $\text{cd}(S)$  cannot come from a  $r \times r$  SD submatrix of  $S_{\text{red}}$ . To conclude the proof, note that given  $S_i = S_{\text{red}}[\alpha, \beta] \in \mathcal{N}$ , the term  $\det(S_{\text{red}}[\alpha, \beta]) \det(U_{\text{red}}[\beta, \alpha])$  will contribute at least  $\min\{m_-(U_i), m_+(U_i)\} = m(U_i)$  terms of sign  $(-1)^{d-1}$  in  $\text{cd}(S)$  and at most  $\max\{m_-(U_i), m_+(U_i)\} = t(U_i) - m(U_i)$  terms of sign  $(-1)^{d-1}$ . (Here  $U_i := U_{\text{red}}[\beta, \alpha]$ .) ■

These bounds are often tight as the next examples illustrate.

### 3.6.1. Examples.

**Proposition 3.19.** *Let  $S$  be a  $d \times d'$  matrix of rank  $r$  with generic  $S_{\text{red}}$ .*

- (1) *Suppose  $S_{\text{red}}$  has no e-cycle interlacing with respect to a perfect matching, then  $\text{cd}(S)$  has no anomalous signs.*
- (2) *If  $\text{cd}(S)$  has no anomalous signs, then  $G(U_{\text{red}})$  has no e-cycles interlacing with respect to a perfect matching.*

*Proof.* (1) By assumption and Theorem 2.6, any  $r \times r$  submatrix  $S_0 = S_{\text{red}}[\alpha, \beta]$  of  $S_{\text{red}}$  is SD. Then  $\mathcal{N} = \emptyset$ , so by Theorem 3.18,  $\text{cd}(S)$  will have no anomalous signs.

To see why (2) is true, we invoke Theorem 2.6. Such an e-cycle and the perfect matching in  $G(U_{\text{red}})$  pick out a  $r \times r$  submatrix  $U_{\text{red}}[\beta, \alpha]$  of  $U_{\text{red}}$ . The corresponding summand in (3.10) will then yield at least one anomalous sign by Theorem 2.6. ■

In the fully reversible case this yields a necessary and sufficient condition for  $\text{cd}(S)$  to have no anomalous signs.

*Remark 3.20.* We recall that for  $\text{cfd}(S)$  what we have just done is known [CF06] in the fully reversible case  $S = \begin{bmatrix} S_{\text{red}} & -S_{\text{red}} \end{bmatrix}$ . What is shown in [CF06], implies that  $\text{cfd}(S)$  has no anomalous signs if and only if  $G(S_{\text{red}})$  has no e-cycles. ■

*Example 3.21.* Suppose  $S_{\text{red}}$  is generic,  $S = \begin{bmatrix} S_{\text{red}} & -S_{\text{red}} \end{bmatrix}$  and the graph  $G(S_{\text{red}})$  is:



There are  $n$  rows and  $n$  columns, so the rank of  $S$  (and  $S_{\text{red}}$ ) is  $n$ .  $G(S_{\text{red}})$  supports exactly one rank  $n$  square matrix,  $S_{\text{red}}$  itself.

$G(S_{\text{red}})$  has one cycle with no c-pairs, so it is an e-cycle.  $G(S_{\text{red}})$  admits 2 perfect matchings: the e-cycle interlaces both matchings. So by Theorem 2.6, we get  $\mathcal{N} = \{S_{\text{red}}\}$ .

Theorem 3.18 together with Theorem 2.6 imply

$$1 = m(U_{\text{red}}) = \sum_{\mathcal{N}} m(U_i) \leq m(S) \leq \sum_{\mathcal{N}} [t(U_i) - m(U_i)] = t(U_{\text{red}}) - m(U_{\text{red}}) = 2 - 1 = 1.$$

Thus generically  $\text{cd}(S)$  has one anomalous sign (independent of  $n \geq 2$ ).

Alternative to Theorem 3.18, since  $S_{\text{red}}$  is square, we could have used Theorems 3.15 and 2.6 which tell us that  $\text{cd}(S)$  will have 2 terms, one with a positive and one with a negative sign.

On the other hand, the number of anomalous signs in  $\text{cfd}(S)$  increases rapidly with  $n$ .

$n$		2	3	4	5	6	7	8	9	10
# of anomalous signs in $\text{cfd}(S)$		1	2	5	13	34	89	233	610	1597

This data is consistent with

$$\text{number of anomalous signs} = \text{Fib}(2n - 3)$$

(see the website <http://www.research.att.com/~njas/sequences/>), where  $\text{Fib}(k)$  denotes the  $k$ th Fibonacci number. We conjecture that the formula is true for all  $n$ . ■

*Example 3.22.* Suppose  $S = \begin{bmatrix} S_{\text{red}} & -S_{\text{red}} \end{bmatrix}$ ,  $S_{\text{red}}$  is generic and  $G(S_{\text{red}})$  is the graph:

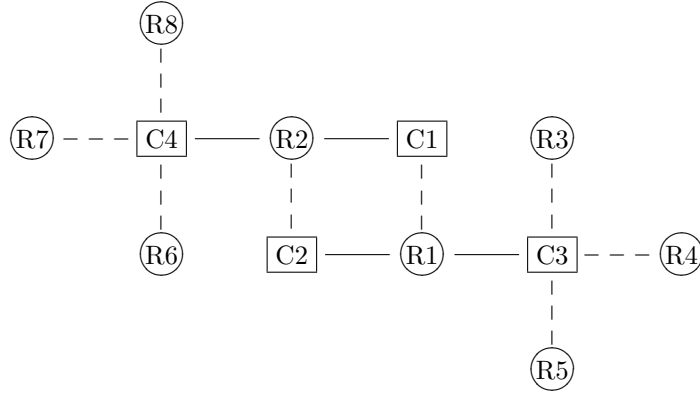

There are 8 rows and 4 columns, so rank of  $S$  and  $S_{\text{red}}$  is 4. The graph  $G(S_{\text{red}})$  has one e-cycle.

$G(S_{\text{red}})$  admits  $3 \cdot 3 \cdot 2 = 18$  perfect matchings and the e-cycle is interlacing with respect to every one of those. Each perfect matching selects a  $4 \times 4$  submatrix of  $S_{\text{red}}$  (or  $U_{\text{red}}$ ) with one e-cycle in its graph. In total there are 9 such submatrices (each in  $\mathcal{N}$ ) with the graph of each one admitting two perfect matchings.

Theorems 3.18 plus 2.6 imply

$$9 = \sum_{\mathcal{N}} m(U_i) \leq m(S) \leq \sum_{\mathcal{N}} [t(U_i) - m(U_i)] = 9(2 - 1) = 9.$$

Thus generically  $\text{cd}(S)$  has 9 anomalous signs. ■

**3.7. Few Anomalous Signs - An Algorithm.** We have just looked at bounds for the number of anomalous signs in  $\text{cd}(S)$  for generic  $S_{\text{red}}$ . A small number of anomalous signs in the core determinant can be handled *precisely* using an algorithm we now describe which obtains *necessary and sufficient conditions for  $\text{cd}(S)$  to have (zero or) one anomalous sign.*

**3.7.1. The zero-one anomalous sign algorithm.** Suppose  $S$  is a  $d \times d'$  matrix of rank  $r$ . In order for the algorithm to work with certainty, we assume  $S_{\text{red}}$  is generic. Let  $\mathcal{N}$  be the set of all  $r \times r$  submatrices of  $S_{\text{red}}$  that are not SD. Given  $S_i \in \mathcal{N}$  we use  $U_i$  to denote the corresponding submatrix of  $U_{\text{red}}$ . We present the algorithm only for the case when  $\text{cd}(S)$  has no anomalous signs or the anomalous sign is  $(-1)^{d-1}$ .<sup>1</sup>

<sup>1</sup>This assumption is made purely for convenience of exposition. In fact, if  $S_{\text{red}}$  has at least two SNS  $r \times r$  submatrices with nonsingular corresponding submatrices in  $U_{\text{red}}$ , then this will automatically be the case.



Case E:  $\mathcal{N}$  has 0 elements.

Then  $\text{cd}(S)$  has no anomalous signs.

Case N:  $\mathcal{N}$  is nonempty.

Subcase (a): All the  $U_i$  corresponding to  $S_i \in \mathcal{N}$  are SD.

Take  $\det(S_i) \det(U_i)$  and look at its sign. If for all  $S_i \in \mathcal{N}$  this sign is  $(-1)^r$ , then  $\text{cd}(S)$  has no anomalous signs. Otherwise for some  $S_i \in \mathcal{N}$  the sign is  $(-1)^{r-1}$  and the corresponding term  $\det(S_i) \det(U_i)$  contributes  $t(U_i)$  terms with sign  $(-1)^{r-1}$  to  $\text{cd}(S)$ . If  $t(U_i) > 1$ , then there is more than one anomalous sign in  $\text{cd}(S)$ . If there is  $S_j \neq S_i$  with  $\text{sign}(\det(S_j) \det(U_j)) = (-1)^{r-1}$ , then  $\text{cd}(S)$  will have more than one anomalous sign. Otherwise  $\text{cd}(S)$  has one anomalous sign.

Subcase (b): There is exactly one  $S_0 \in \mathcal{N}$  for which the corresponding  $U_0$  is not SD.

If there is  $S_i \in \mathcal{N} \setminus \{S_0\}$  with the sign of  $\det(S_i) \det(U_i)$  equal to  $(-1)^r$ , then  $\text{cd}(S)$  will have more than one anomalous sign. Otherwise we use the det sign test (Theorem 2.6) to compute  $m(U_0)$ .

(i) If  $m(U_0) > 1$ , then  $\text{cd}(S)$  will have more than one anomalous sign.

(ii) Suppose  $m(U_0) = 1$ . If  $t(U_0) = 2$ ,  $\text{cd}(S)$  will have one anomalous sign. So suppose  $t(U_0) > 2$ . Let

$$\epsilon = \begin{cases} +1 & | \quad m(U_0) = m_+(U_0) \\ -1 & | \quad \text{otherwise.} \end{cases}$$

Now  $\text{cd}(S)$  will have one anomalous sign if and only if

$$(3.11) \quad \epsilon \text{ sign } \det(S_0) = (-1)^{r-1}.$$

(If (3.11) fails,  $\text{cd}(S)$  will have more than one anomalous sign.)

Subcase (c): There are at least two  $S_i \in \mathcal{N}$  for which the corresponding  $U_i$  is not SD.

In this case  $\text{cd}(S)$  will have at least two anomalous signs.

**Lemma 3.23.** *The zero-one anomalous sign algorithm computes whether or not there is one (respectively no) anomalous sign.*

*Proof.* Case E is described in Proposition 3.19. Case N.(a) follows directly from the Binet-Cauchy formula (3.10). For Case N.(b).(i),  $\det(S_0) \det(U_0)$  has more than one anomalous sign, so  $\text{cd}(S)$  will have more than one anomalous sign. The proof of Case N.(b).(ii) is essentially contained in the statement itself. Finally, in the Case N.(c) two different  $S_i$  contribute two different terms to the Binet-Cauchy expansion 3.10 for  $\text{cd}(S)$  each having at least one anomalous sign. ■

*Remark 3.24.* The algorithm simplifies considerably in the fully reversible case, as then  $U_i$  is SD if and only if  $S_i$  is. Thus Case N.(a) cannot arise. Subcase (b) is equivalent to  $\mathcal{N}$  having exactly one element and Subcase (c) is equivalent to  $\mathcal{N}$  containing at least two elements. ■

*Example 3.25.* Let  $S = [ \begin{array}{cc} S_{\text{red}} & -S_{\text{red}} \end{array} ]$ , where

$$S_{\text{red}} = \begin{bmatrix} a & 1 & 0 \\ 1 & 1 & 1 \\ -1 & 0 & 1 \\ 0 & 1 & 0 \end{bmatrix}$$

has rank 3 and  $a \in \mathbb{R}_{>0}$ . Suppose  $a \neq 2$ ; this makes  $S_{\text{red}}$  generic. The graph  $G(S_{\text{red}})$  is given by the following:

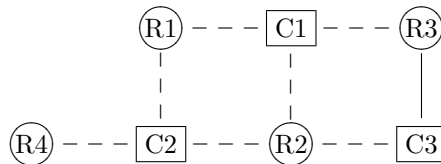

The cycle  $R1-C1-R2-C2-R1$  has two c-pairs and is an e-cycle; it is the only e-cycle and it interlaces two perfect matchings. Both leave out  $R4$  and select the same  $3 \times 3$  submatrix  $S_0$  of  $S_{\text{red}}$ . Hence  $\mathcal{N} = \{S_0\}$ .

To count the number of anomalous signs in  $\text{cd}(S)$  apply the Algorithm 3.7.1. Our situation corresponds to Case N.(b) and we compute  $m(U_0)$ , where  $U_0$  is the  $3 \times 3$  submatrix of  $U_{\text{red}}$  corresponding to  $S_0$ . By the det sign test,  $m(U_0) = 1$  and  $t(U_0) = 3$ . It is easy to see that  $m(U_0) = m_-(U_0)$ ; thus by the zero-one anomalous sign algorithm,  $\text{cd}(S)$  will have one anomalous sign if and only if  $a - 2 = \det(S_0) < 0$ . (If  $a > 2$ ,  $\text{cd}(S)$  will have two anomalous signs.) ■

Another class of examples is solipsistic cycles, a notion we now elucidate. A subgraph  $\Gamma$  of  $G$  is said to be **solipsistic** provided when edges of  $\Gamma$  are removed from  $G$  all paths in the remaining graph starting from a vertex in  $\Gamma$  have length  $\leq 1$ .

**Proposition 3.26.** *Suppose  $S_{\text{red}}$  is generic and the graph  $G(S_{\text{red}})$  is connected and contains at most one cycle which is solipsistic (e.g. Example 3.5 or Example [CF05, Table 1.1.(iii)]). Then the number of anomalous signs in  $\text{cd}(S)$  is  $\leq 1$ .*

*Proof.* Without loss of generality,  $G(S_{\text{red}})$  contains a cycle  $\mathcal{E}$ . If  $\mathcal{E}$  is not an e-cycle, then we are in Case E of the algorithm and there are no anomalous signs in  $\text{cd}(S)$ . Thus we assume that  $\mathcal{E}$  is an e-cycle.

By Lemma 3.11, the rank  $r$  of  $S_{\text{red}}$  is the minimal number of rows or of columns in  $S_{\text{red}}$ . If  $r$  is bigger than the number of columns appearing in the cycle, then we are in Case E of the algorithm because any perfect matching will include some edge not in the cycle, thus making  $\mathcal{E}$  not interlace it. Hence  $\text{cd}(S)$  has no anomalous signs.

Otherwise  $r$  equals the number of columns appearing in the cycle. Then  $\mathcal{N}$  has only one element  $S_0$ . The corresponding submatrix  $U_0$  of  $U_{\text{red}}$  is either SD or its determinant expansion has two terms of opposite sign. Now the result follows from Case N.(a). ■

Note that results on the core determinant  $\text{cd}(S)$  given in this section have parallels for the Craciun-Feinberg determinant expansion  $\text{cfd}(S)$  which are easy to work out using the techniques in our paper.

#### 4. CHEMICAL MOTIVATION

This matrix theory paper is not directly aimed at producing chemical results but was inspired as an extension of the striking work of Craciun and Feinberg. We hope these extensions might someday prove valuable on chemical network problems and some methods they combine with are described in [CHW08] and a consequence is Theorem 4.1 below.

Now we turn to describing the connection between the core determinant from §3 and chemistry.

A chemical reactor can be thought of as a tank with each chemical species flowing in (assume at a constant rate) and each species flowing out (assume in proportion to its concentration in the tank). If the reaction inside the tank satisfies  $\frac{dx}{dt} = g(x)$ , then when there are inflows and outflows, the total reaction satisfies

$$\frac{dx}{dt} = f(x) = g(x) + \varepsilon x_{\text{in}} - \delta x.$$

The Craciun-Feinberg determinant is the determinant of the Jacobian  $f'$  when  $\delta$  is 1 and it bears on counting the number of equilibria for this differential equation, cf. [CF05, CF06, CHW08]. There is some discussion of small outflows vs. no outflows in [CF06iee].

The core determinant bears on a different problem. Assume the differential equation has reaction form  $f(x) = Sv(x)$ . Let  $R$  (respectively  $R^\perp$ ) denote the range of  $S$  (respectively its orthogonal complement);  $R$  is typically called the stoichiometric subspace. Let  $P$  be the projection onto  $R$  and  $P^\perp$  onto  $R^\perp$ . With no inflows and outflows,  $P^\perp f(x) = 0$  and clearly this implies the solution  $x(t)$  to the differential equation propagates on the affine subspace

$$(4.1) \quad \mathcal{M}_{x^0} := \{x \mid P^\perp x(t) = \text{const} = P^\perp x^0\}.$$

This reflects quantities (like the number of carbon atoms) being conserved. The flow on  $\mathcal{M}_{x^0}$  has dynamics  $\frac{dPx}{dt} = \frac{d(Px+P^\perp x^0)}{dt} = Pf(Px + P^\perp x^0)$ . Proposition 3.3 implies that the determinant of the Jacobian of this dynamics is the core determinant which we studied in this paper, namely, for any  $\xi$  in  $\mathcal{M}_{x^0}$

$$(4.2) \quad \text{cd}(S)(\xi) = \det(Pf'(\xi)P).$$

When  $\text{cd}(S)$  has no anomalous signs the degree theory arguments in §3 of [CHW08] give a strong result for numbers of equilibria of the differential equation.

**Theorem 4.1.** *Suppose  $\frac{dx}{dt} = f_b(x) := Sv^b(x)$  has reaction form with  $v^b(x)$  once continuously differentiable in  $x$  and depending continuously on a parameter  $0 \leq b \leq 1$ . Suppose each component  $v_j^b(x)$  of  $v^b(x)$  is monotone nondecreasing. Suppose  $\mathcal{M}_{x^0}$  is compact. Suppose  $\text{cd}(S)$  has no anomalous signs.*

*If there are no zeroes  $f_b(x) = 0$  for any  $b$  and any  $x$  on the boundary of  $\mathcal{M}_{x^0}$ , then the number of zeroes for  $f_b$  in the interior of  $\mathcal{M}_{x^0}$  is independent of  $b$ .*

The hypothesis that  $\text{cd}(S)$  has no anomalous signs can be weakened to  $\text{cd}(S)(\xi)$  does not equal 0 for any  $\xi$  in  $\mathcal{M}_{x^0}$ .

## 5. APPENDIX. A SIGN PATTERN TIMES ITS TRANSPOSE

This paper derived matrix theoretic results pertaining to a chemistry setup. In this section we describe similar results in a different mathematical context which some might find more attractive.

**Theorem 5.1.** *Let  $A$  be a sign pattern and  $B$  its transposed sign pattern. Then  $AB$  has a sign pattern if and only if  $A$  does not contain a  $2 \times 2$  submatrix whose rows and columns can be permuted to obtain a matrix whose sign pattern is one of*

$$(5.1) \quad \begin{bmatrix} +1 & -1 \\ -1 & -1 \end{bmatrix} \quad \text{or} \quad \begin{bmatrix} -1 & +1 \\ +1 & +1 \end{bmatrix}.$$

*Proof.* This is easily proved using a straightforward analysis of  $(AB)_{ij} = \sum_k A_{ik}B_{kj}$  similar to that found in the proof of Theorem 3.2.(2). ■

*Remark 5.2.* Note that Theorem 5.1 implies Theorem 3.2.(3) in the case  $S$  is fully reversible, i.e.,  $S = \begin{bmatrix} S_{\text{red}} & -S_{\text{red}} \end{bmatrix}$ . Indeed, by Lemma 3.14,  $SU = S_{\text{red}}U_{\text{red}}$  and  $U_{\text{red}}$  is the transpose of the sign pattern of  $-S_{\text{red}}$ . Now apply Theorem 5.1 to  $S_{\text{red}}$ .

In a similar vein what we have done bears on the determinant expansions of  $AB$  where  $A$  is a sign pattern and  $B$  is its transpose pattern. If  $A$  is a total signed compound sign pattern, as in §2.2, and  $B$  is its transpose sign pattern, then  $AB$  is sign-nonsingular provided it is invertible. This follows from the Binet-Cauchy formula (similar to §3.3), and the idea is essentially in [CF05, CF06, BDB07]. When  $AB$  is not invertible, then the core determinant expansion introduced here has all coefficients of the same sign. What we do in this paper is more general in that it gives estimates on the number of anomalous signs in the expansion of  $\det(AB)$ . However, we specialize to  $A$  not actually being a sign pattern but having numerical entries, and  $B$  being the sign pattern which is the transpose of the signs of  $A$ .

## 6. APPENDIX. SOFTWARE

The discovering of the results in this paper was considerably facilitated by computer experiments. The programs we wrote to do this might be of value to a broad community, so we documented them and provided tutorial examples. They are found on the web site

<http://www.math.ucsd.edu/~chemcomp/>

The Mathematica files provided contain software for dealing with equations that come from chemical reaction networks;  $dx/dt = f(x) = Sv(x)$  as in (1.2). Some of our commands focus on the the Jacobian,  $f'$ , of  $f$ ; they do the following

- (1) compute the Jacobian  $f'$  of  $f$  (given say the stoichiometric matrix  $S$ );
- (2) compute the Craciun-Feinberg determinant of  $f'$ ;
- (3) compute the core determinant of  $f'$ ;
- (4) check existence of a sign pattern for  $f'(x)$  which remains unchanged for all  $x \geq 0$ , using Theorem 5.1 in this paper;
- (5) implement the sign fixing algorithm explained in [HKKprept].

Another part of our Mathematica package deals with deficiency of reaction form differential equations and various representations for these differential equations. Capability to automatically plot planar graphs is under development and should be available soon.

#### REFERENCES

- [AnS03] D. Angeli, E. D. Sontag: Monotone control systems. New directions on nonlinear control. *IEEE Trans. Automat. Control* 48 (2003), no. 10, 1684–1698
- [ArS06] M. Arcac, E.D. Sontag: Diagonal stability of a class of cyclic systems and its connection with the secant criterion. *Automatica*, 42 (2006), no. 9, 1531–1537
- [ArS07] M. Arcac, E.D. Sontag: A passivity-based stability criterion for a class of interconnected systems and applications to biochemical reaction networks. *Mathematical Biosciences and Engineering*, to appear.  
<http://arxiv.org/abs/0705.3188>
- [BJS98] M. Bakonyi, C.R. Johnson, D.P. Stanford: Sign pattern matrices that require domain-range pairs with given sign patterns, *Linear and Multilinear Algebra* 44 (1998), no. 2, 165–178
- [BDB07] M. Banaji, P. Donnell, S. Baigent:  $P$  Matrix Properties, Injectivity, and Stability in Chemical Reaction Systems, *SIAM J. Appl. Math.* 67 (2007), no. 6, 1523–1547
- [BMQ68] L. Bassett, J. Maybee, J. Quirk: Qualitative economics and the scope of the correspondence principle. *Econometrica* 36 (1968), 544–563
- [BS95] R.A. Brualdi, B.L. Shader: *Matrices of sign-solvable linear systems*, Cambridge Univ. Press, 1995
- [CJ06] P.J. Cameron, C.R. Johnson: The number of equivalence classes of symmetric sign patterns, *Discrete Math.* 306 (2006), no. 23, 3074–3077
- [CF05] G. Craciun, M. Feinberg: Multiple equilibria in complex chemical reaction networks. I. The injectivity property, *SIAM J. Appl. Math.* 65 (2005), no. 5, 1526–1546
- [CF06] G. Craciun, M. Feinberg: Multiple equilibria in complex chemical reaction networks. II. The species-reaction graph, *SIAM J. Appl. Math.* 66 (2006), no. 4, 1321–1338
- [CF06iee] G. Craciun, M. Feinberg: Multiple Equilibria in Complex Chemical Reaction Networks: Extensions to Entrapped Species Models, *IEE Proceedings Systems Biology* 153:4 (2006), 179–186
- [CHW08] G. Craciun, J.W. Helton, R.J. Williams: Homotopy methods for counting reaction network equilibria, *Math. Biosci.* **216** (2008), 140–149
- [DGESVD99] J. Demmel, M. Gu, S. Eisenstat, I. Slapničar, K. Veselić, Z. Drmač: Computing the singular value decomposition with high relative accuracy, *Linear Algebra Appl.* 299 (1999), no. 1-3, 21–80
- [HKKprept] J.W. Helton, V. Katsnelson, I. Klep: Sign patterns for chemical reaction networks, preprint (2009)
- [HGBM06] L. Hogben, R. Brualdi, A. Greenbaum, R. Mathias (Eds.): *Handbook of Linear Algebra*, Discrete Mathematics and Applications, vol. 39, CRC Press, 2006
- [KOSD07] I.-J. Kim, D.D. Olesky, B. Shader, P. van den Driessche: Sign patterns that allow a positive or nonnegative left inverse, *SIAM J. Matrix Anal. Appl.* 29 (2007), no. 2, 554–565
- [LMOD96] T. Lundy, J.S. Maybee, D.D. Olesky, P. van den Driessche: Spectra and inverse sign patterns of nearly sign-nonsingular matrices, *Linear Algebra Appl.* 249 (1996), 325–339
- [Pa06] B. Palsson: *Systems Biology: Properties of Reconstructed Networks*, Cambridge Univ. Press, 2006
- [RST99] N. Robertson, P.D. Seymour, R. Thomas: Permanents, Pfaffian orientations, and even directed circuits, *Ann. of Math.* (2) 150 (1999), no. 3, 929–975

J. WILLIAM HELTON, MATHEMATICS DEPARTMENT, UNIVERSITY OF CALIFORNIA AT SAN DIEGO, LA JOLLA CA 92093-0112

*E-mail address:* [helton@ucsd.edu](mailto:helton@ucsd.edu)

IGOR KLEP, UNIVERZA V LJUBLJANI, FAKULTETA ZA MATEMATIKO IN FIZIKO, JADRANSKA 19, SI-1111 LJUBLJANA, AND UNIVERZA V MARIBORU, KOROŠKA 160, SI-2000 MARIBOR, SLOVENIA

*E-mail address:* [igor.klep@fmf.uni-lj.si](mailto:igor.klep@fmf.uni-lj.si)

RAUL GOMEZ, MATHEMATICS DEPARTMENT, UNIVERSITY OF CALIFORNIA AT SAN DIEGO, LA JOLLA CA 92093-0112

*E-mail address:* [r1gomez@math.ucsd.edu](mailto:r1gomez@math.ucsd.edu)

## NOT FOR PUBLICATION

## CONTENTS

1. Introduction	1
1.1. Determinants of Sign Patterns	1
1.2. Jacobians of reaction form differential equations	2
1.3. Chemistry	2
2. Matrices with sign patterns	3
2.1. Basics on graphs, matrices and determinants	3
2.2. SNS matrices vs. e-cycles	4
2.3. Many Cycles: Square Matrices	4
2.3.1. <b>Proof of Theorem 2.6</b>	6
2.4. Many Cycles: Nonsquare Matrices	8
3. Reaction form differential equations and the Jacobians	9
3.1. Sign pattern of the Jacobian	9
3.2. The core and other determinant expansions	10
3.3. Formulas for determinants of products of matrices	12
3.4. Generic matrices and the reduced $S$ -matrix	13
3.5. Counting anomalous signs when $S_{\text{red}}$ is square	14
3.6. Rectangular $S_{\text{red}}$ matrices	14
3.6.1. <b>Examples</b>	15
3.7. Few Anomalous Signs - An Algorithm	16
3.7.1. <b>The zero-one anomalous sign algorithm</b>	16
4. Chemical Motivation	18
5. Appendix. A sign pattern times its transpose	19
6. Appendix. Software	19
References	20